

# HOME TRAINING IN CABINET WORK: PRACTICAL EXAMPLES IN STRUCTURAL WOOD WORKING: NINETEENTH OF THE SERIES

## CHILD'S OPEN BOOKCASE



ONE of the great difficulties in attaining a tidy nursery is often that there is no place where children can easily put things away themselves. Closet-doors are hard to open and the shelves too high to be of use. Wall shelves and brackets are usually purposely out of reach, and the nursery table is apt to be full.

This child's open bookcase is planned especially to meet this nursery problem; there are no doors and the shelves are broad and low enough to be within the reach of very little children. The shelves are not adjustable but put in stoutly with tenon and key so that they are never out of place and never need attention. All furniture in a child's room should be well finished to avoid the slightest chance of splinters or scratches. It is a nice idea to finish the bookcase in harmony with the other woodwork of the nursery, unless this is in a bright tone; in which case a beautiful soft, harmonious wood tone would be best. This piece of furniture could also be used in a library or sewing-room.

### MILL BILL OF STOCK FOR OPEN BOOKCASE

Pieces	No.	Rough			Finish	
		Long	Wide	Thick	Wide	Thick
Sides .....	2	40 in.	10½ in.	1⅛ in.	10 in.	1 in.
Top .....	1	20 in.	11 in.	1 in.	10½ in.	⅞ in.
Back .....	1	36 in.	16 in.	¾ in.	15½ in.	½ in.
Shelves .....	3	16½ in.	10 in.	1 in.	16 in.	⅞ in.
Stretchers .....	2	18½ in.	8 in.	1¼ in.	pattern	1⅛ in.

# HOME TRAINING IN CABINET WORK

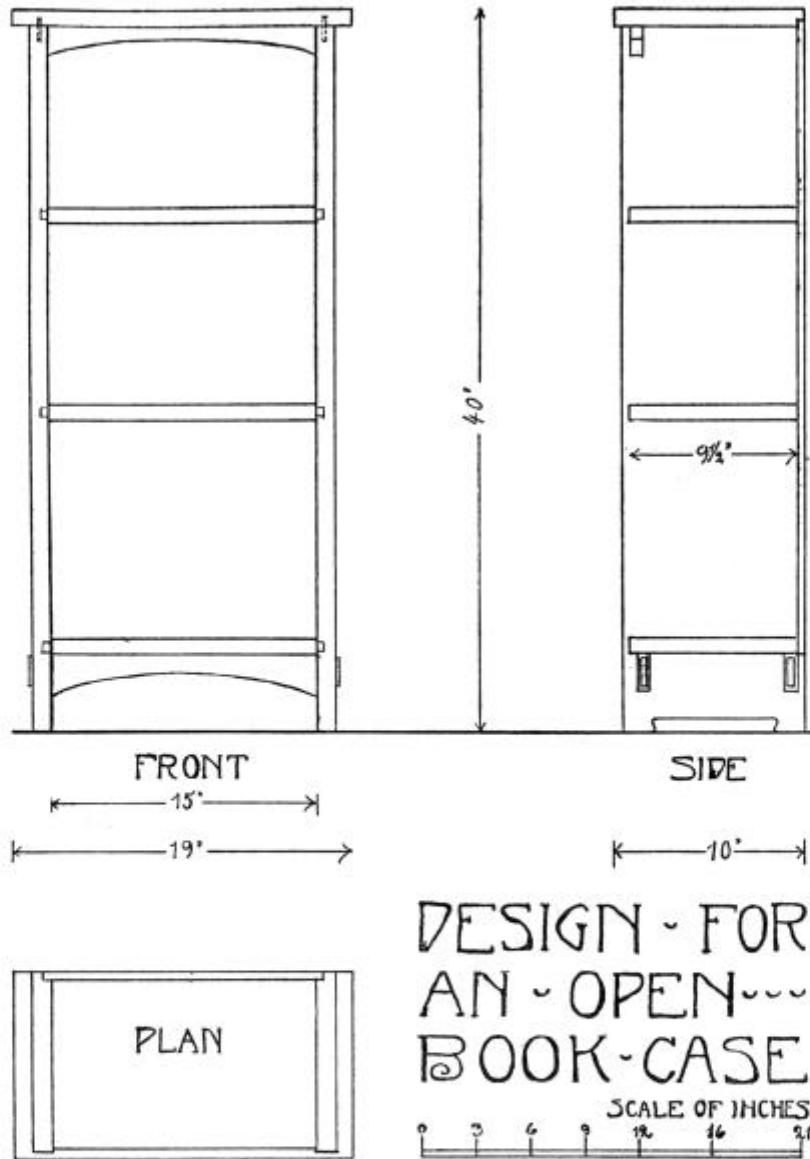

# HOME TRAINING IN CABINET WORK

## SPINDLE-BED FOR CHILD

**F**ROM the time a child graduates from a crib, this design of a small Craftsman bed is appropriate. It is made after the new spindle pattern which is so popular in other models of Craftsman furniture. Although having the effect of a grown-up bed, it is, nevertheless, enough smaller than the standard adult size to delight a child for years. This bed is planned to be made in the most substantial fashion, and is put together in the same durable way as the finest piece of grown-up furniture. It is made low so that a child can easily get in and out without help. As with all other children's furniture, the home cabinet-maker is advised to finish as carefully as possible to avoid any injury to little nursery folk. The most complete detail for the making of this piece of furniture is given in the working plan on the opposite side of the page.

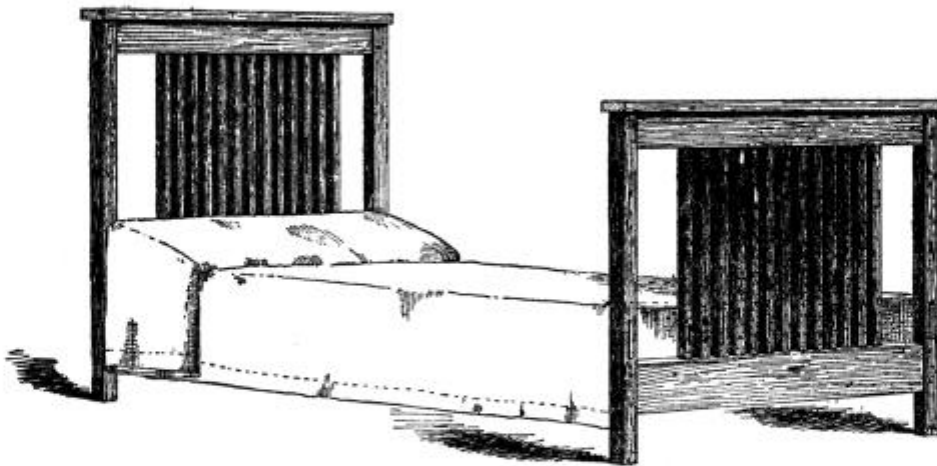

MILL BILL OF STOCK FOR CHILD'S BED

Pieces	No.	Rough			Finish	
		Long	Wide	Thick	Wide	Thick
Posts .....	2	44 in.	2 $\frac{1}{4}$ in.	2 $\frac{1}{4}$ in.	2 in.	2 in.
Posts .....	2	34 in.	2 $\frac{1}{4}$ in.	2 $\frac{1}{4}$ in.	2 in.	2 in.
Top .....	2	38 in.	3 $\frac{1}{2}$ in.	1 $\frac{1}{4}$ in.	3 in.	1 in.
Top rails .....	2	36 in.	4 in.	1 $\frac{1}{4}$ in.	3 $\frac{1}{2}$ in.	1 $\frac{1}{8}$ in.
Lower rails .....	2	36 in.	5 $\frac{1}{2}$ in.	1 $\frac{1}{4}$ in.	5 in.	1 $\frac{1}{8}$ in.
Spindles .....	13	32 in.	1 $\frac{1}{8}$ in.	1 $\frac{1}{8}$ in.	1 in.	1 in.
Spindles .....	13	22 in.	1 $\frac{1}{8}$ in.	1 $\frac{1}{8}$ in.	1 in.	1 in.
Side rails .....	2	5 x 11 in.	6 $\frac{1}{2}$ in.	1 $\frac{1}{4}$ in.	6 in.	1 $\frac{1}{8}$ in.

HOME TRAINING IN CABINET WORK

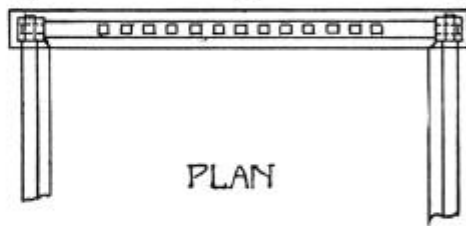
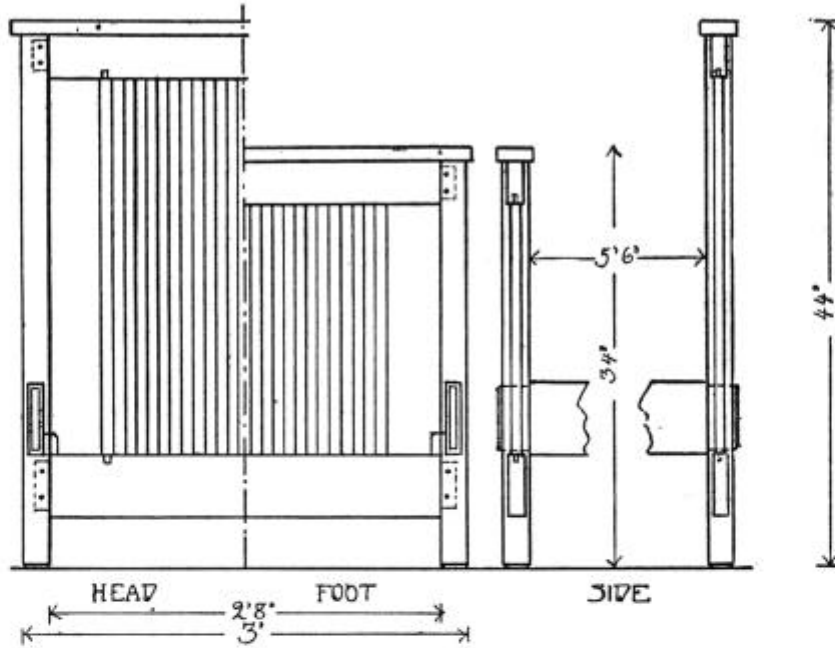

DESIGN FOR A  
CHILD'S BED

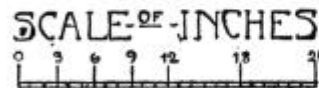

## HOME TRAINING IN CABINET WORK

### CHILD'S SETTLE

**L**ITTLE children always like simple, primitive things. This is proven every day when the boy neglects his costly mechanical toys for home-made contrivances of sticks and strings, and the little girl lavishes all her love on the unbeautiful but substantial rag-doll. This is because revealed construction always appeals to the direct mind of a child, and the furniture intended for its use is most comfortable when it partakes somewhat of the characteristics of the home-made toy. This does not mean that furniture intended for the use of children should be roughly made or crude, only that it must be strong and simple if it is to become a part of beloved surroundings. The settle shown here is of this order of furniture, and can easily be made at home by any one handy with tools. It is firmly put together with mortise and tenons and no amount of lusty tumbling and romping could put it out of commission.

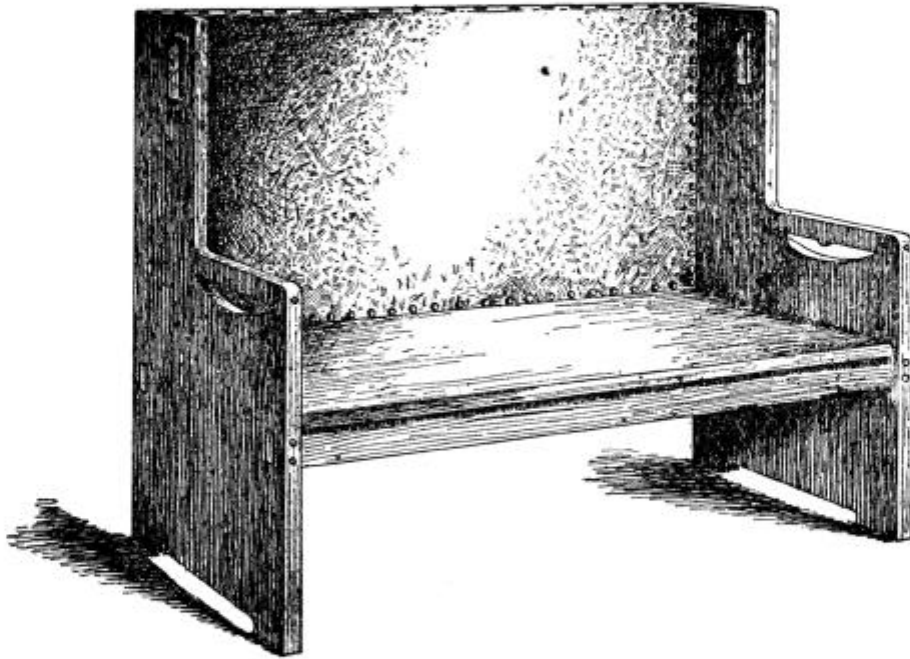

MILL BILL OF STOCK FOR CHILD'S SETTLE

Pieces	No.	Rough			Finish	
		Long	Wide	Thick	Wide	Thick
Ends .....	2	37 in.	21 in.	1¾ in.	pattern	1½ in.
Seat .....	1	44 in.	19½ in.	1¼ in.	19 in.	1⅛ in.

## HOME TRAINING IN CABINET WORK

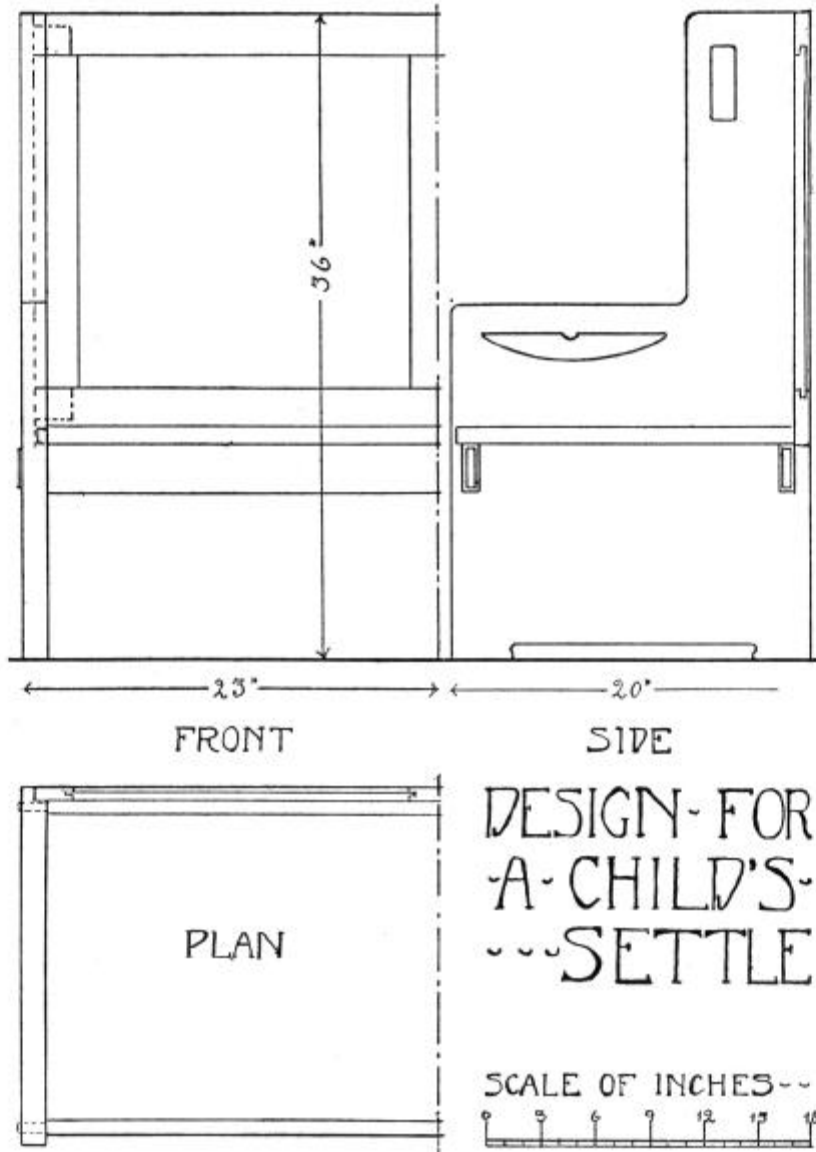

Seat stretcher . . . . .	2	47 $\frac{1}{4}$ in.	3 $\frac{1}{2}$ in.	1 $\frac{1}{4}$ in.	3 in.	1 $\frac{1}{8}$ in.
Top rail . . . . .	1	47 in.	3 in.	1 in.	2 $\frac{1}{2}$ in.	$\frac{7}{8}$ in.
Lower rail . . . . .	1	47 in.	4 in.	1 in.	3 $\frac{1}{2}$ in.	$\frac{7}{8}$ in.
Stiles . . . . .	3	28 in.	3 in.	1 in.	2 $\frac{1}{2}$ in.	$\frac{7}{8}$ in.

# HOME TRAINING IN CABINET WORK

## CHILD'S DRESSER

**T**HERE are no gifts which children appreciate so much and so long as furnishings for their own room, and a complete room can be fitted up without much expense if every birthday and Christmas brings an article of furniture. And if this furniture can be made by some member of the family, a child's delight is doubled.

The Craftsman bureau shown on this page is intended to be made with the utmost care, so that finished, it would be beautiful and durable and a life-long possession. In the plans shown on the opposite page you will see that every detail is carefully worked out. The drawers are all made with dust panels underneath, and it is intended that the inside finish of them should be fine and velvety. By careful study of the working-plan, such a dresser could be put together by any amateur cabinet-maker.

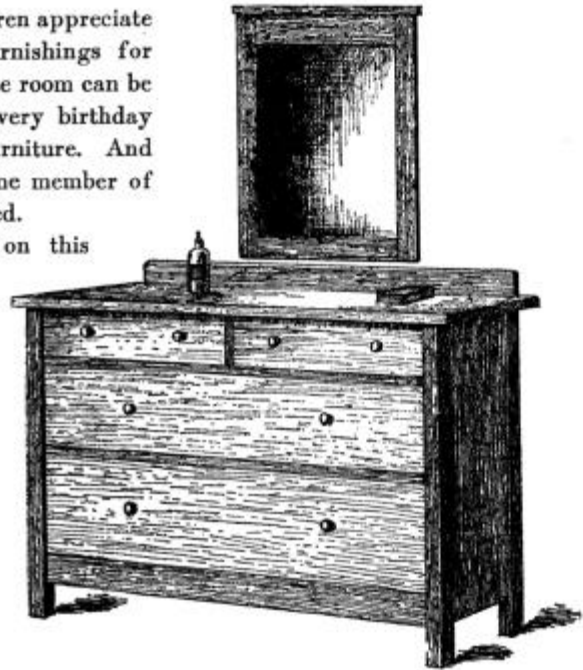

### MILL BILL OF STOCK FOR CHILD'S DRESSER

Pieces	No.	Rough			Finish	
		Long	Wide	Thick	Wide	Thick
Posts .....	4	30 in.	2 $\frac{1}{4}$ in.	2 $\frac{1}{4}$ in.	2 in.	2 in.
Top .....	1	43 in.	20 $\frac{1}{2}$ in.	1 $\frac{1}{8}$ in.	20 in.	1 in.
Sides .....	2	26 in.	18 in.	1 in.	17 $\frac{3}{4}$ in.	$\frac{7}{8}$ in.
Drawer fronts .....	2	18 in.	4 $\frac{1}{2}$ in.	1 in.	4 in.	$\frac{7}{8}$ in.
Drawer sides .....	4	18 $\frac{1}{2}$ in.	4 $\frac{1}{2}$ in.	$\frac{3}{4}$ in.	4 in.	$\frac{1}{2}$ in.
Drawer backs .....	2	18 in.	4 $\frac{1}{2}$ in.	$\frac{3}{4}$ in.	3 $\frac{3}{4}$ in.	$\frac{1}{2}$ in.
Drawer bottoms ....	2	17 $\frac{1}{2}$ in.	17 $\frac{1}{2}$ in.	$\frac{5}{8}$ in.	17 $\frac{1}{4}$ in.	$\frac{1}{2}$ in.
Drawer front .....	1	37 in.	7 $\frac{1}{2}$ in.	1 in.	7 $\frac{1}{4}$ in.	$\frac{7}{8}$ in.
Drawer sides .....	2	18 $\frac{1}{2}$ in.	7 $\frac{1}{2}$ in.	$\frac{3}{4}$ in.	7 $\frac{1}{4}$ in.	$\frac{1}{2}$ in.
Drawer backs .....	1	37 in.	7 $\frac{1}{2}$ in.	$\frac{3}{4}$ in.	7 in.	$\frac{1}{2}$ in.
Drawer bottoms ....	1	36 $\frac{1}{2}$ in.	17 $\frac{1}{2}$ in.	$\frac{5}{8}$ in.	17 $\frac{1}{4}$ in.	$\frac{1}{2}$ in.
Drawer front .....	1	37 in.	9 $\frac{1}{2}$ in.	1 in.	9 in.	$\frac{7}{8}$ in.

## HOME TRAINING IN CABINET WORK

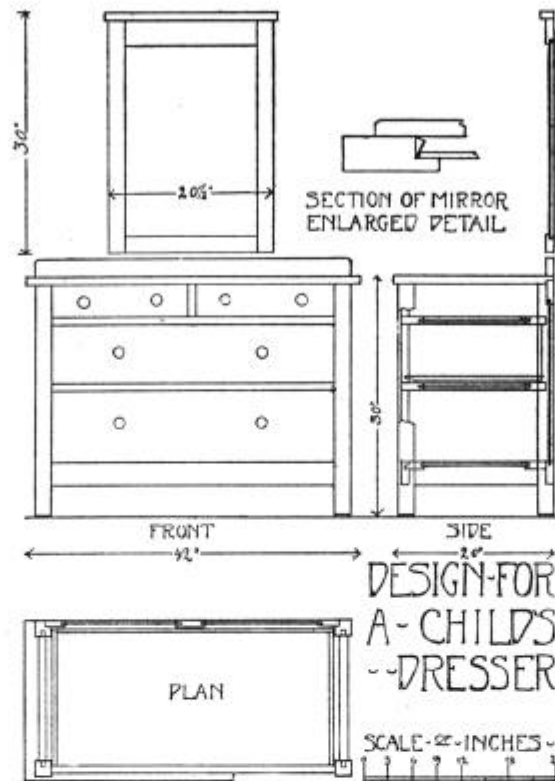

Drawer sides	2	18 1/2 in.	9 1/2 in.	3/4 in.	9 in.	1/2 in.
Drawer backs	1	37 in.	9 1/2 in.	3/4 in.	8 3/4 in.	1/2 in.
Drawer bottoms	1	36 1/2 in.	17 1/2 in.	5/8 in.	17 1/4 in.	1/2 in.
Back rails	2	38 in.	8 3/4 in.	1 in.	8 1/2 in.	3/4 in.
Back stiles	3	27 in.	8 3/4 in.	1 in.	8 1/2 in.	3/4 in.
Back panels	2	21 in.	21 in.	1/2 in.	20 in.	3/8 in.
Division rails	6	38 in.	8 1/2 in.	1 in.	8 in.	3/4 in.
Ledger rails	7	19 in.	8 1/2 in.	1 in.	8 in.	3/4 in.

### MILL BILL OF STOCK FOR MIRROR

Pieces	No.	Rough			Finish	
		Long	Wide	Thick	Wide	Thick
Top	1	22-in.	2 in.	1 in.	1 3/4 in.	7/8 in.
Top rail	1	19 1/2 in.	8 1/2 in.	1 in.	8 1/4 in.	7/8 in.
Lower rail	1	19 1/2 in.	2 1/4 in.	1 in.	2 in.	7/8 in.
Stiles	2	29 1/2 in.	2 1/4 in.	1 in.	2 in.	7/8 in.